



Project:

Item:

Quantity:

MEGA T-280

VACUUM PACKAGING MACHINE



FEATURES

- Seal bar length: 11"
- Seal bar with two wires, for double security
- Seal bar easily removable for cleaning and maintenance purposes
- Pump capacity: 338 cf (10 m³/h) Busch vacuum pump
- Pump maintenance and cleaning program
- Machine cycle: 25-35 sec
- Time control 1- 99 sec
- Transparent lid, which opens automatically after every cycle
- Deep drawn vacuum chamber
- Comes with insert plates for a faster cycle and product adjustment
- Stainless steel exterior
- 6ft cord with Nema 5-15P plug
- Standard with service kit

DESCRIPTION

The robust, stainless steel Mini Jumbo vacuum packer is standard equipped with a Busch vacuum pump. The machine is ETL listed and complies with UL, CSA and CE standards.

OPTIONS AND ACCESSORIES

- Cut-off/Wide seal
- High hood lid: 5"
- Inclined insert plate
- Food container adaptor
- Cart with castors and shelf



WARRANTY

Pack 3000 offers a warranty of 1 year on labor and 3 years on parts. For full warranty details, please refer to www.pack3000.com

DATE

APPROVAL



PACK 3000
Sales and technical support

sales@pack3000.com

VACUUM PACKING MACHINE MEGA T-280 – SPECS

VACUUM PACKING MACHINE MEGA T-280 – SPEC SHEET

DIMENSIONS

In inches

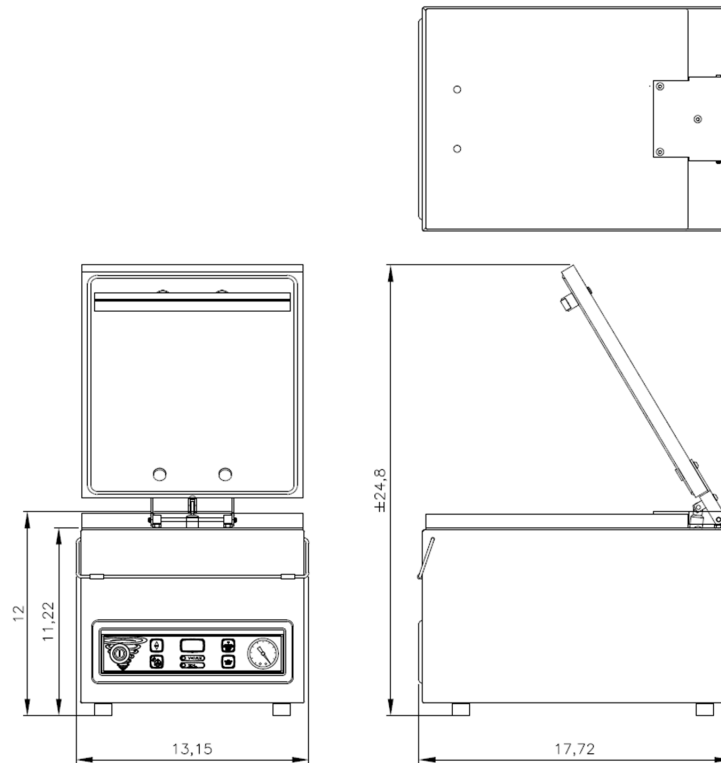

| Model | Dimensions (inches) | | Volts | Amps | Hz | Pump capacity | HP | Plug | Weight (lbs) |
|------------|--------------------------------|-----------------|----------|------|------|---------------------------------|-----|------------|--------------|
| | Chamber (usable space) (LxWxH) | Machine (LxWxH) | | | | | | | |
| Mega T-280 | 12"x11"x3.3" | 17.7"x13.2"x12" | 110-120V | 6.5 | 60Hz | 338 cf/h (10 m ³ /h) | 0.7 | NEMA 5-15P | 70 |

NEMA 5-15P



15 A/125 V



PACK 3000
Sales and technical support

sales@pack3000.com