



Project:  
Item:  
Quantity:

**MEGA T-350  
CHAMBER VACUUM SEALER**



**FEATURES**

- Seal bar length: 13.5"
- Seal bar with two wires, for double security
- Seal bar easily removable for cleaning and maintenance purposes
- Pump capacity: 678 cf/h (19 m<sup>3</sup>/h) Busch vacuum pump
- Pump maintenance and cleaning program
- Machine cycle: 15-30 sec
- Soft Air to protect the product and vacuum pouch
- Transparent lid, which opens automatically after every cycle
- Deep drawn vacuum chamber
- Comes with insert plates for a faster cycle and product adjustment
- Stainless steel exterior
- 6ft cord with Nema 5-15P plug
- Standard with service kit

**DESCRIPTION**

The robust, stainless steel MEGA T-350 vacuum sealer is standard equipped with a Busch vacuum pump. This Combivac table-top model is ETL listed and complies with UL, CSA and CE standards.

**OPTIONS AND ACCESSORIES**

- Liquid control
- Inclined insert plate
- Cut-off seal (\$0)
- Wide seal (\$0)
- Label printer
- Food container adaptor
- Cart with castors and shelf



**WARRANTY**

Pack 3000 offers a warranty of 1 year on labor and 3 years on parts. For full warranty details, please refer to [www.pack3000.com](http://www.pack3000.com)

DATE

APPROVAL



PACK 3000  
Sales and technical support  
[sales@pack3000.com](mailto:sales@pack3000.com)

# VACUUM PACKING MACHINE MEGA T-350 – SPECS

VACUUM PACKING MACHINE MEGA T-350 – SPEC SHEET

## DIMENSIONS

In inches

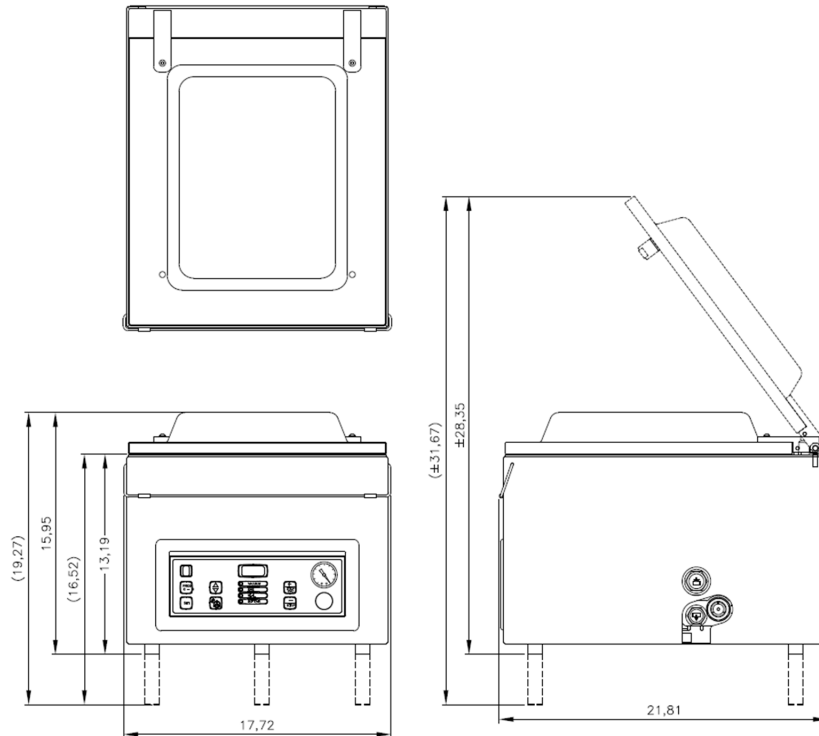

Model	Dimensions (inches)		Volts	Amps	Hz	Pump capacity	HP	Plug	Weight (lbs)
	Chamber (usable space) LxWxH	Machine LxWxH							
Mega T-350	14.5"x13.5"x6"	21.8"x17.7"x15.9"	110-120V	9.5	60Hz	678 cf/h (19 m <sup>3</sup> /h)	0.74	NEMA 5-15P	115

NEMA 5-15P



15 A/125 V



PACK 3000  
Sales and technical support

[sales@pack3000.com](mailto:sales@pack3000.com)